

KENDRIYA VIDYALAYA KAILASHAHAR

KAMRANGABARI, GOURNAGAR, UNAKOTI TRIPURA -799282

F.No.3-4/ADVT/KV-KLS/2017-18/572, Dated 01/01/2018

Cost of Form: - 200/-

Date of sale:-

To, _____

TERM & CONDITION OF TENDER

1. Sealed bids for the supply and fitting & fixing of Furniture items are invited from registered firms/manufactures/ dealers by the Principal Kendriya Vidyalaya Kailashahar, up to 1700 hrs on 15/01/2018 in the sealed cover marked as “Bid for the supply and fitting & fixing of Furniture”, as per enclosed list and not by the name. The bids will be opened in the office of the undersigned at 1100 hrs. on 16/01/2018. However, in case the date of opening is declared a Government Holiday, the tenders will be opened on following working day at scheduled time 1100 hrs.
2. The quotations shall be submitted according to the terms and conditions specified in paragraphs 1 to 24 and specification, size and design illustrated and enclosed herewith, unless specified otherwise in the quotation, it shall be construed that the terms and conditions stipulated hereunder have been agreed to.
3. The rates quoted must be F.O.R. including transportation cost, all taxes as applicable, freight, fitting & fixing charges, labour charges and any other rates or imposition whatever liable in respect of the supplies freight etc. No extra payment will be made other than the rate quoted. GST at specified rates must be expressly stipulated in the quotation. Only in the event of acceptance of the quotation supply order will be issued to the firm. The responsibility of mentioning correct rate lies with the firm/Tenderer.
4. There should not be any overwriting or corrections in the quotation. If a figure is to be amended, it should be neatly scored out, the revised figure should be written above and the same should be attested with full signature by the same signatory, who signed the quotations, in the absence of the attested corrections the quotations is liable to be rejected.
5. The undersigned does not bind himself to accept the lowest quotation and reserves the right to accept the quotation in whole or in part i.e., with respect to all the articles mentioned in the attached statement or in respect of any one or more than on article specified in the attached statement
6. The tenderer shall pay or deposit EMD of Rs.25000/- through Bank Demand Draft/Cheque/NEFT/RTGS as detail specified above. Tenders without payment of the stipulated EMD shall be rejected forthwith. The same will be refunded in the event of rejection of quotation. The earnest money will be forfeited in the event of failures to comply with the contract. In the event of acceptance of the quotation, the earnest Money will be adjusted towards Security Deposit/ Performance

Signature of the bidder with stamp

1/11

Security which shall be payable @ 10% of the total approximate cost. The quotations without Earnest Money Deposit, whatsoever, will not be accepted in accordance with Article 180(iv) of the Accounts Code of KVS. However the firm/ supplier registered under Article- 150 of GFR-2017, with KV Kailashahar are exempted from depositing earnest money.

Account Name – VVN Account of KV Kailashahar

Account No. – 11540059151

Bank and branch- SBI, Kailashahar

IFSC- SBIN0005592

7. On acceptance of the quotation, it will become a contract and the contractor shall be bound by the terms and conditions of the quotation. If the contractor fails to supply the article/ provide services within the time stipulated in the letter of acceptance by the undersigned, the undersigned shall be at liberty to purchase the article from the market or get the rest of the contract completed by any other person(s) or firm and the difference of price, if any shall be deducted from the earnest money/ security deposit and in case any amount in excess of the security deposit is paid by the undersigned, the contractor shall be liable to pay this amount.
8. The quantity of articles indicated in the attached statement may be increased or decreased at the discretion of the undersigned without assigning any reason.
9. In the event of acceptance of the quotation and placing of the order for purchase, the articles would be subjected to an inspection by the undersigned or his representatives and are liable to be rejected if the articles to be supplied are not according to the approved samples or do not confirm to the specification prescribed.
10. The rates quoted by the contractor shall hold good up to One Year i.e.16/01/2018. No amendment in the rate except increase in the rates of GST/applicable tax during the period of execution of the contract will be accepted.
11. The samples of the articles for which rates are invited will be called in office and inspected between 10.00 am to 04.00 pm on any working day (except Saturdays/ Sundays/ Holidays) with prior intimation to firms.
12. Along with the quotation a copy of the Certificate of GST registration, trade license valid up to date and Income Tax clearance Certificate is required to be submitted. The quotation of unregistered firm will not be accepted.
13. These instructions are to be signed by the bidders and returned with the bid.
14. Sealed envelope will be opened on 16/01/2018 at 1100 hrs in the office of the undersigned in the presence of bidders, if any. Further, decision regarding supply and fitting & fixing of Furniture items will be taken up the committee after inspection of the articles, specification, quality etc. and decision of the committee shall be final. If the tender is accepted, the payment of the Bill as per the approved rates of the articles will be made by Cheque/NEFT/RTGS only.
15. Income Tax will be deducted as per Income Tax Act & Rules.
16. Tenderer will have to supply the articles within 15 days of the issue of supply order.
17. TOLERANCE CLAUSE
It is further clarified that the quantities for the said materials and its pages as shown in the volume of work, may get varied. Hence, the purchaser reserves the right for ten percent (10%) plus/ minus in the quantities of the articles while placing the supply order as the rates to be quoted are for the estimated quantities only.

Signature of the bidder with stamp

2/11

18. UNRESPONSIVE TENDERS

The following kind of tenders will be treated as unresponsive tenders” –

- i) Not meeting the qualifying criteria i.e., carrying required financial/ solvency status, regd., with the appropriate authorities for carrying out the described works, furnishing the declaration regarding blacklisting on stamp paper etc.
- ii) Tender not enclosed with the required DD/ PO of EMD amount of Rs.25, 000/- and fee amount of Rs.200/-. If applied on downloaded document, except notified otherwise.
- iii) Unsigned tender document/ terms & conditions / pricing bid document.
- iv) The specification of the paper attached with the tender document not found of the quality asked for.
- v) The tenderer not agreeing to any of the terms & conditions so listed.

19. AWARD OF CONTRACT

- (a) The purchaser will award the contract to the bidder whose quotation has been determined to be substantially responsive and who has offered the lowest price.
- (b) The bidder whose bid is accepted will be notified of the award of the contract by the office prior to expiration of the quotation validity period.
- (c) The Notification of award to clearly specify any change in the unit price or any other terms conditions accepted.
- (d) Normal commercial warranty/ guarantee shall be applicable to the supplied goods.
- (e) Payment be made within 30 days after the delivery of goods and their acceptance.
- (f) Notwithstanding the above, the purchaser reserves the right to accept or reject any quotations and to cancel the bidding process and reject all quotations at any time prior to the contract.

20. **Specification, size of the Items to be purchased are mentioned in rate contract and diagram.**

21. Tender document includes term and condition as above and tender form enclosed herewith for specific items.
22. All the dispute and differences arise if any will be resolved in the Jurisdiction of Kailashahar.
23. I/We accept all the terms and conditions of tender document.
24. The bidder should carry an onsite comprehensive warranty/guarantee of Furniture for a period of at least 12(twelve) months.

Signature of the Authorized Signatory of the Agency

Date:-

(With seal of the Agency affixed)

Place:-

Full Name of the signatory

DESIGN OF FURNITURE FOR COMPUTER LAB



DESIGN OF FURNITURE FOR MUSIC & GAMS ROOM



Assignment - 2

DESK FOR CLASS IX TO XII
GOLDEN BROWN TOP

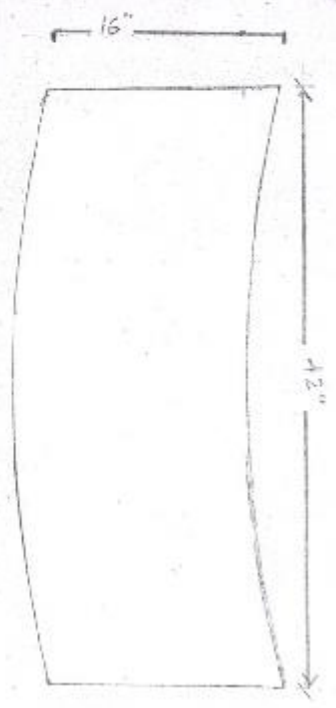

TOP VIEW

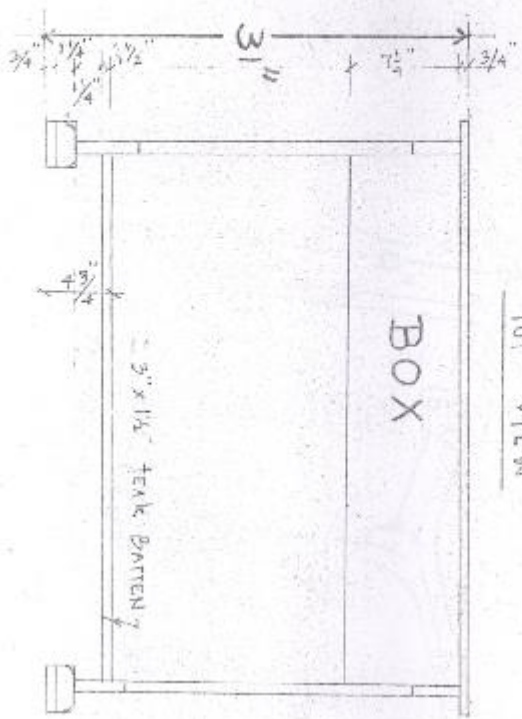

FRONT VIEW

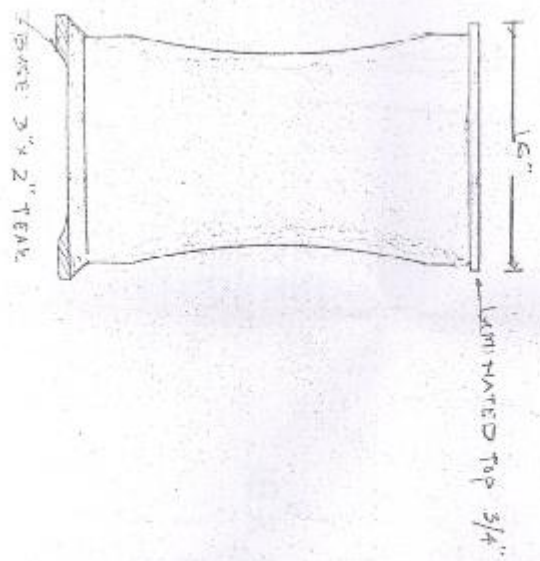

SIDE VIEW

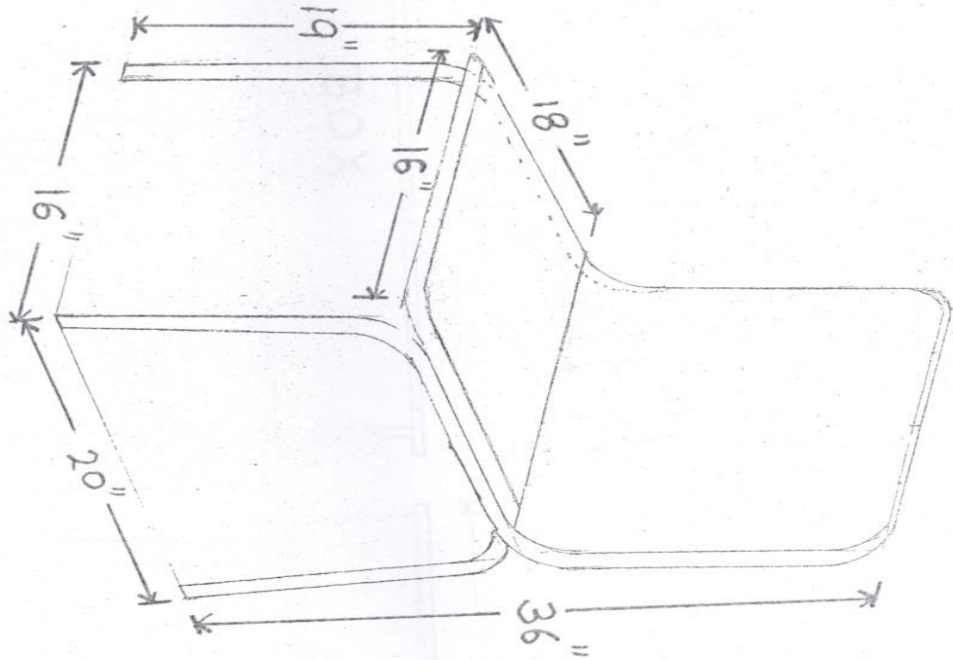

CHAIR FOR CLASS IX TO XII

SEAT 18 X 16"
 HEIGHT 19"
 BACK FROM G.L. 36"

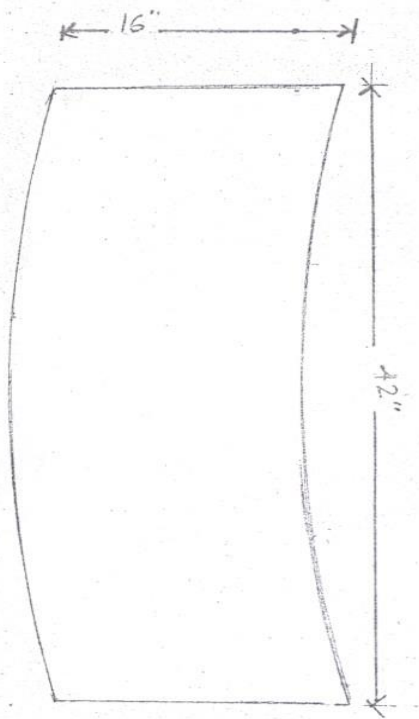

TOP VIEW

DECK FOR CLASS III TO V
PINK TOP

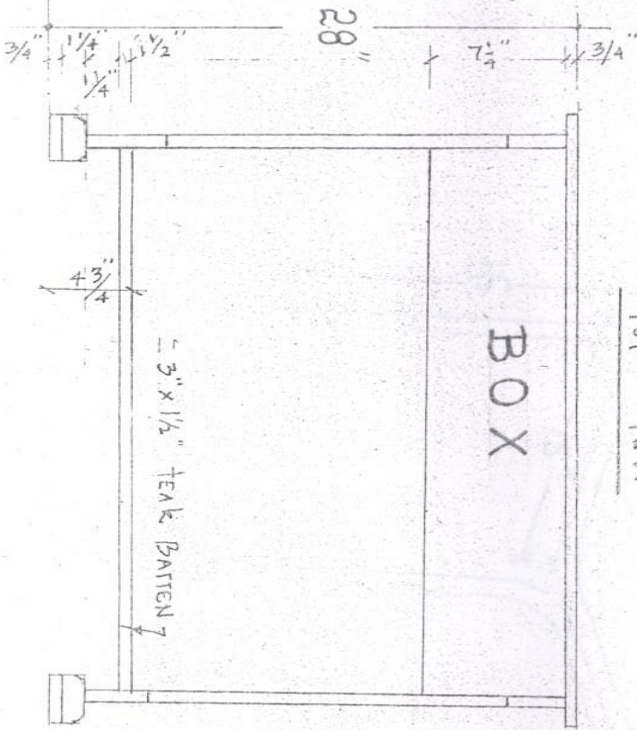

FRONT VIEW

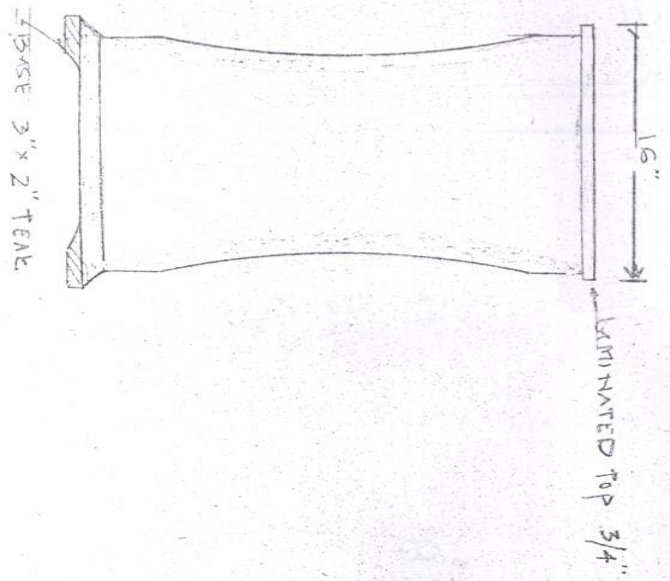

SIDE VIEW

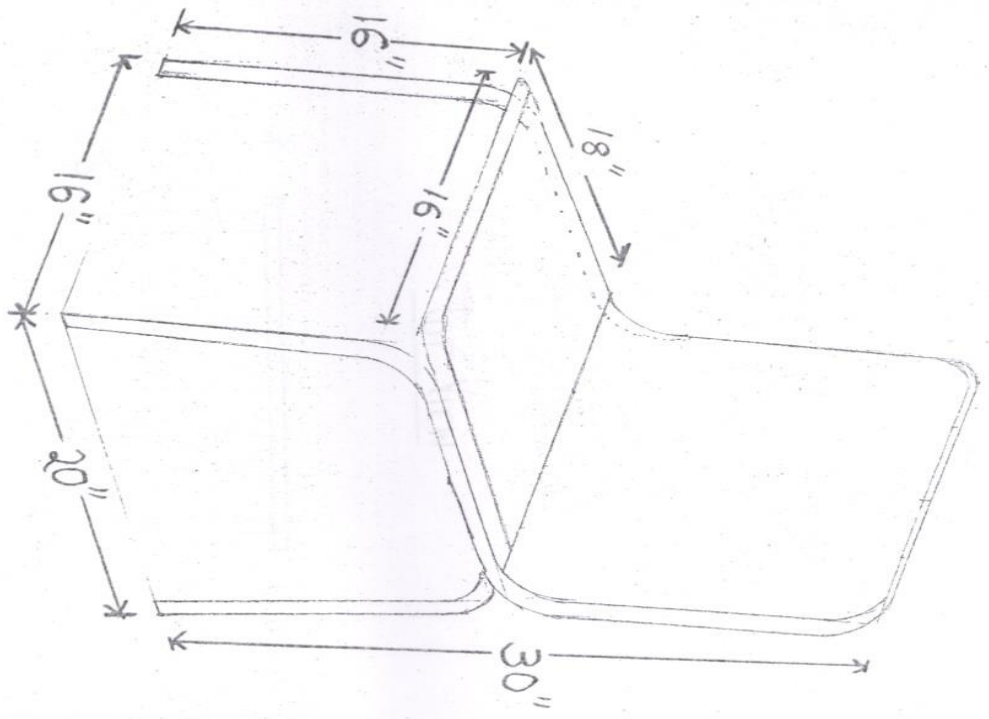

CHAIR FOR CLASS III TO V

SEAT 18 X 16"
 HEIGHT 16"
 BACK FROM G.L. 30"

PROFORMA FOR PRICE SCHEDULE
BID FOR PURCHASE (SUPPLY, FITTING & FIXING) OF FURNITURE
AT K.V. KAILASHAHAR

COMPUTER LAB

Sl no	Items	Qty	Rate Per sq ft	Tax	Gross per Sq fit
1	Wall mounted computer table: made with 19 mm branded Polymer sheet/board with .8mm sunmica pasted provision for keeping keyboard, CPU & UPS and with polished. Size H-2.5 ft X L- 81.5 ft	204 sq ft (approx)			
2	Long computer table: made with 19 mm branded Polymer sheet/board with .8mm sunmica pasted provision for keeping keyboard, CPU & UPS and with polished Size H-2.5 ft X L- 20 ft X 2 table	100 sq ft (approx)			
3	Chairs for Computer Lab- Revolving without arm rest (branded)	50 Nos			

LIBRARY

Sl no	Items	Qty	Rate Per sq ft	Tax	Gross per Sq fit
1	Wall mounted bookshelf: : made with 19 mm branded Polymer sheet/board with .8mm sunmica pasted provision for keeping book, magazine with front sliding glass door and with duly polished, fitting including handle and lock. Size H-3 ft X L- 52 ft	156 sq ft (approx)			
2	Wall mounted table: : made with 19 mm branded Polymer sheet/board with .8mm sunmica pasted provision for keeping book, magazine with front glass door and with duly polished, fitting including handle and lock. Size H-8 ft X L- 32 ft	256 sq ft (approx)			
3	Long library table: made with 19 mm branded Polymer sheet/board with .8mm sunmica pasted and with duly polished. Size H-2.5 ft X L-3 ft x 2 ft.	42.5 sq ft (approx)			
4	Circulation counter made with 19 mm branded Polymer sheet/board with .8mm sunmica pasted and front opening door (four) with drawer (six) and shelf (three) duly polished, fitting including handle and lock. Size: H- 2.5 ft X L-7 ft	17.5 sq ft (approx)			

MUSIC ROOM

Sl no	Items	Qty	Rate Per sq ft	Tax	Gross per Sq fit
1	Wall mounted wooden shelf: made with 19 mm branded Polymer sheet/board with .8mm sunmica pasted and with duly polished. Inside wooden shelf for keeping music items of different size and with half sliding glass door of size- 3.5 ft H- 7 ft X L-19 ft	133 sq ft (approx)			

SPORTS AND GAMES ROOM

Sl no	Items	Qty	Rate Per sq ft	Tax	Gross per Sq fit
1	Wall mounted wooden shelf: made with 19 mm branded Polymer sheet/board with .8mm sunmica pasted and with duly polished. Inside wooden shelf for keeping sports items of different size. Size: H- 7 ft X L- 19 ft	133 sq ft (approx)			

CLASS ROOM

Sl no	Items	Qty	Rate Per sq ft/Nos	Tax	Gross per Sq fit
1	DUAL DESKS & CHAIRS made of wood/with 19 mm branded Ply wood/board with .8mm sunmica pasted and with duly polished. Size: as mentioned in the attached diagram	50 nos			

It is hereby certified that we have understood all the terms and conditions specified in the tender document and are thoroughly aware of the nature of job required to be done and goods/items to be supplied. We agree to abide by all the tender terms and conditions. We hereby offer to supply the goods/items detailed above as you specify in the notification of award.

Place:

(Signature and seal of Bidder)

Dated:

NAME IN BLOCK LETTERS:

WARRANTY/GUARANTEE CERTIFICATE

We hereby undertake to furnish one year (12months) onsite warranty-guarantee and free maintenance service from the date of fixing & fitting.

Signature and Seal of tenderer Date:

Full Name Place: